



FALL CITY HISTORICAL SOCIETY

P.O. Box 293, Fall City, WA 98024

fallcityhistorical@juno.com

www.fallcityhistorical.org

What is it? Train Order Hoop

Our October speaker, Allen Miller (right), introduced us to a mysterious object, the **train order hoop**. (See drawings from patent applications below.) It was used for the vital task of passing train orders up to the engineer (at the front) and conductor (at the end) of trains as they slowed, but often did not fully stop at stations. It required the station operator to stand perilously close to the moving train, holding up the hoop so that the engineer, and then the conductor, could catch it on an arm, remove the order clipped in place, and toss the hoop beside the tracks to be retrieved later. All parts of this exchange were difficult, especially at night or in bad weather.

A later version, shown at right, was Y-shaped. It had two small battery-operated lamps at the upper corners to improve visibility, and the message came away with the string, leaving the hoop in place. These hoops could be held in place on a raised post, sparing the station operator the need to approach the moving train but were still difficult in conditions of poor visibility

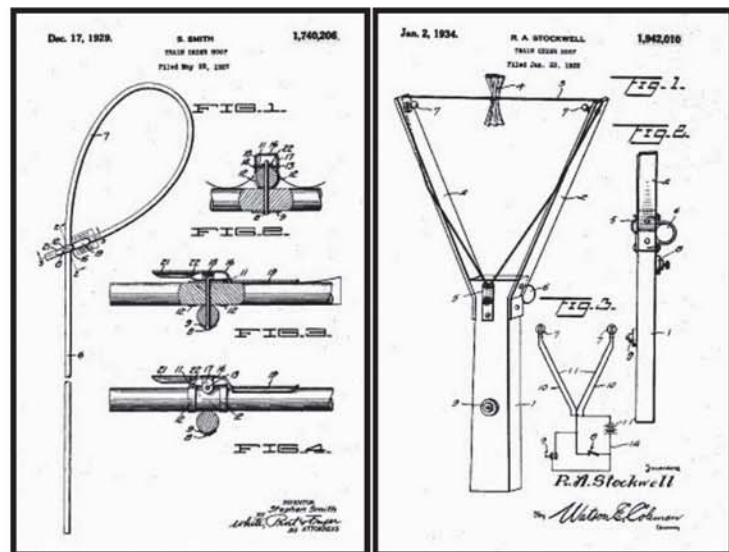

New in the collection: Below is a portion of a wonderful photo shared by Irene Pike, showing the Alexander farm, between Fall City and Carnation. This Darius Kinsey panoramic photo, taken in 1914, is truly a treasure.

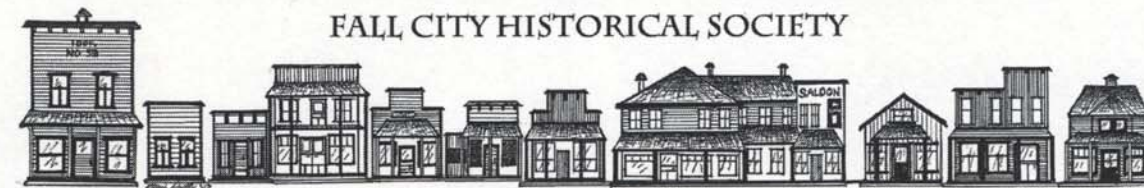

FALL CITY HISTORICAL SOCIETY

P.O. Box 293, Fall City, WA 98024

fallcityhistorical@juno.com

www.fallcityhistorical.org



Farewell and thank you

We have been fortunate for most of 2014 and 2015 to have help from Julie Coulter as a capable Collections Assistant, and are sorry to have her time with us coming to an end. Our thanks to Heritage 4Culture for making her work with us possible.

Julie brought a wonderful depth of experience in Collections Care with her and the ability to quickly track down information in areas with which she was not familiar. With her help, we have redesigned our Collection Room to optimize the amount of storage and create new space for hanging special items (WWI uniform, 1917 Band Uniform, opera caps, etc.) and for rolled storage of our early quilt and a large flag. She has also brought together well-defined procedures for cleaning and pest management for collection areas, as well as helping catalog and write condition reports for a large number of items. Julie has been that wonderful combination of extremely capable and disciplined yet relaxed and a delight to work with.

Our special thanks for all those drives from Ballard to Fall City! We'll miss you.

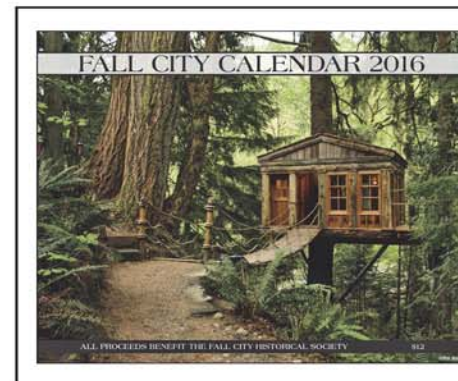

**Come see us on Dec. 5th
At the Holiday Market
and check out the Gift Shop on our website.
CALENDARS ARE SELLING QUICKLY
don't wait too long!**

